

Explore 131 / 171

TECHNICAL INFORMATION

NIR Turbidity Sensors



All brand and product names are registered trademarks of
EXNER PROCESS EQUIPMENT GmbH

Imprint

Issued by:

Exner Process Equipment GmbH

Carl-Metz-Str. 26

D-76275 Ettlingen

Issue date: 2024-10-15

Effective: 01.07.2024

File: Technical information EXplore 131_171 240701

© 2020, Dipl.-Ing. [Graduate Engineer] Detlef Exner

All rights reserved, also for the translation.

The contents of these operating instructions may only be reproduced with written approval from EXNER PROCESS EQUIPMENT GMBH, ETTLINGEN.

All technical specifications, drawings, etc. are subject to copyright protection law.

We reserve the right to make technical changes.

Printed on chlorine and acid-free paper consisting of cellulose pulp.

Table of contents

1	Technical data	4
1.1	Standards	4
1.2	Specification	4
1.3	Dimensions	5
1.4	Environmental conditions	5
1.5	EXplore process conditions	5
1.6	Identification plate	6
2	Product description	7
2.1	EXplore NIR turbidity sensors	7
2.1.1	Components EXplore 131	7
2.1.2	Components EXplore 171	8
2.2	Process integration	9
2.3	Checking the sensors	12
3	Ordering structure	13
3.1	EXplore 131	13
3.2	EXplore 171	14
4	Spare parts and accessories	15
4.1	Accessories	15
4.2	Certificates	15
4.3	Factory inspection	15
4.4	Installation adapter	16
5	Certificates and compliances	18

1 Technical data

1.1 Standards

The following standards were applied when manufacturing the sensor:

- EN 61326-1: 2013-7
- EN 61326-2-3: 2013-7
- DIN/EN 27027 (ISO7027)

1.2 Specification

Sensor specifications	
Measurement range	0...100 %
Resolution	0.1 %
Precision	± 1.5%
Reproducibility	≤ 1 % of the end value
Wavelength	850 nm
Light source	LED
Material	Stainless steel, 1.4435 (316L)
Surface finish	Ra <0.37 µm
Measuring window / Lens	Sapphire
Power supply	24 V DC
Output current	4...20 mA
Cable connection	M12 plug, 3-pin (5-pin also possible)
Process connection	G 1/2" für welding socket with 35 ° conus

1.3 Dimensions

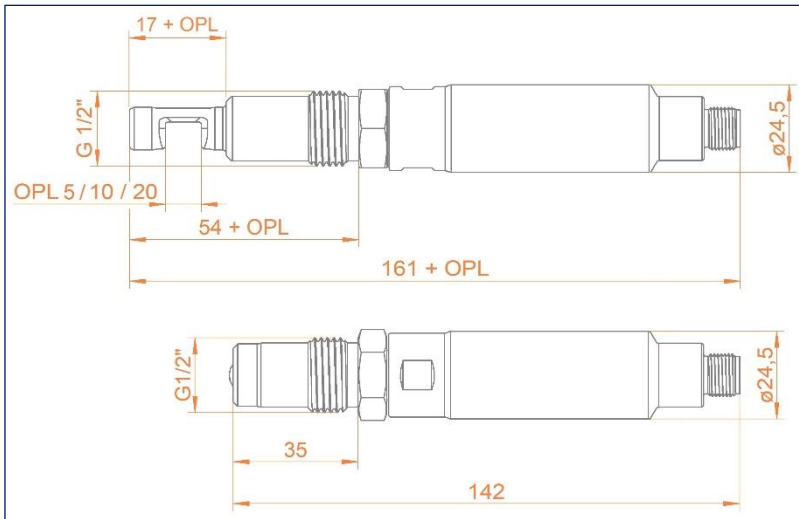

Fig. 1: Dimensions for sensors EXplore 131 (top) and EXplore 171 (bottom)

1.4 Environmental conditions

Ambient temperature -10...70 °C

Transport and storage temperature -20...80 °C

1.5 EXplore process conditions

Max. permissible pressure PS: 16 bar / 232 psi (EXplore 131)
20 bar / 290 psi (EXplore 171)

Max. permissible temperature TS: 90 °C (EXplore 131)
100 °C (EXplore 171)

Max. permissible sterilisation temperature: 135 °C max. 1 hour (EXplore 131)
135 °C max. 2 hours (EXplore 171)

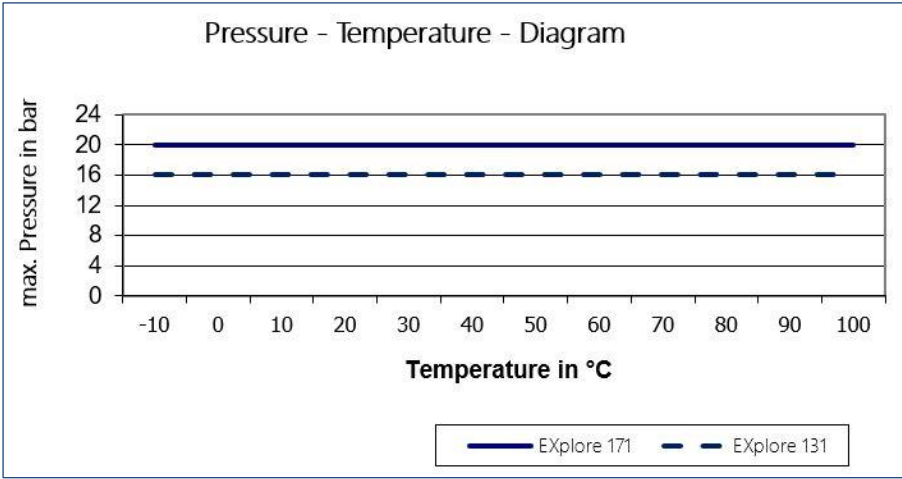

Fig. 2: Pressure temperature diagrams for EXplore

1.6 Identification plate

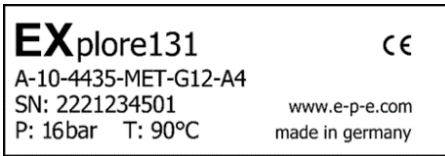

Fig. 3: Identification plate (based on EXplore 131)

In case of queries, please contact your retailer directly.

2 Product description

2.1 EXplore NIR turbidity sensors

2.1.1 Components EXplore 131

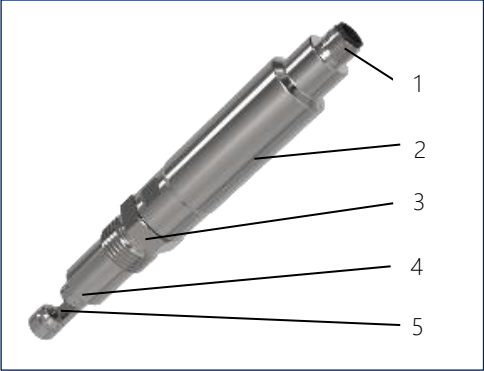

1	M12 plug connection
2	Transmitter
3	Pressure screw
4	Process connection
5	Measuring window

Fig. 4: NIR absorption sensor

EXplore 131

The NIR turbidity sensor EXplore 131 is a 180° absorption sensor which detects the turbidity of liquid in the close infrared range (850 nm wavelength). The sensor is designed to monitor continuous process results or safely show changes. Particularly suitable for phase separation, filter monitoring and concentration measurement.

- Safe phase separation
- Faster product change
- Filter monitoring
- Colour-independent concentration measurement
- Compact design with an integrated amplifier
- Resistant sapphire windows
- Hygienic design, CIP/SIP compliant
- LED light source, guarantees a stable and long-lasting signal

2.1.2 Components EXplore 171

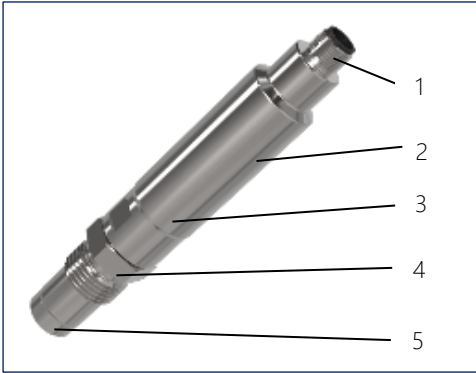

1	M12 plug connection
2	Transmitter
3	Pressure screw
4	Process connection
5	Sapphire lens (spherical)

Fig. 5: NIR backscatter sensor

EXplore 171

The NIR backscatter sensor EXplore 171 is designed to monitor the turbidity of liquids in order to monitor continuous process results or safely show changes. Particularly suitable for phase separation, filter monitoring and concentration measurement.

- Safe phase separation
- Faster product change
- Filter monitoring
- Colour-independent concentration measurement
- Compact design with an integrated amplifier
- Resistant sapphire lens
- Hygienic design, CIP/SIP compliant
- LED light source, guarantees a stable and long-lasting signal

2.2 Process integration

Sensor

The EXplore series sensors are installed directly in pipes or containers via its G ½" process connection or inserted in existing process connections using corresponding adapters. The minimum possible pipe diameter depends on the selected process connection/adaptor as well as the insertion depth of the welding socket or the socket height for a tri-clamp connection.

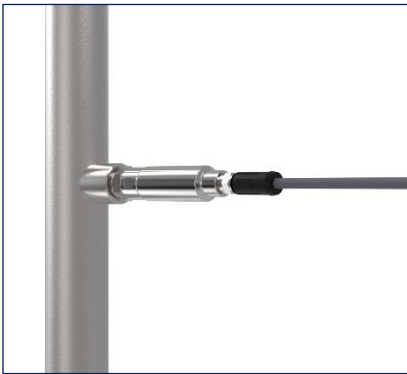
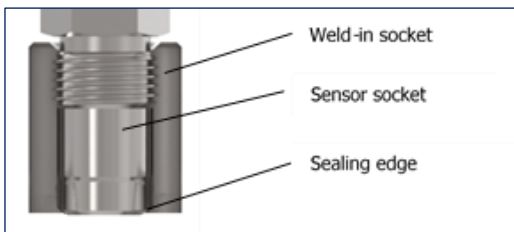

Fig. 6: Process integration

Welding sockets

Assembly using welding sockets guarantees hygienic process adaption which can be applied with minimal dead space and elastomer-free. As the system here uses purely metallic sealing, no further sealing materials such as elastomers may be used.



2 Product description

Please always use the welding aid sockets offered as accessories, so that the heat arising when welding can be safely dissipated and distortion of the borehole can be hindered effectively.



Welding in tanks / pipes

1. Drill a hole with the outer diameter of the welding aid socket (tolerance max. +0.2 mm)
2. Tack-weld the sockets using 4 evenly distributed points (Fig. 1, below)
3. Screw the welding aid sockets in
4. Weld the sections between the 4 points (Fig. 2, below)

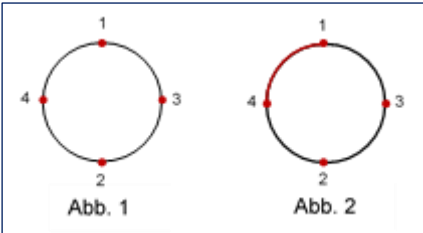
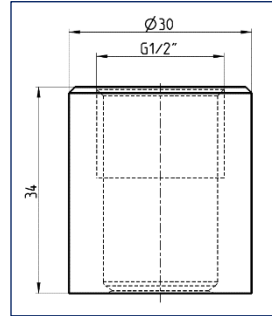

Transmitter

The transmitter is supplied with 24 V DC. It has an 4...20 mA output for measurement value output.

Pressure / Temperature

Depending on the sensor type, only a determined pressure-temperature range may be used. This can be found on the respective pressure/temperature diagram.

In order to protect the LED used, it is switched off as of a temperature of 90 °C (Explore 131) or 100 °C (Explore 171). Measurement is then no longer possible. After reduction of

the media temperature below 90 °C (EXplore 131) or 100 °C (EXplore 171), the LED is reactivated.

NOTE

Please observe the pressure and temperature diagram in → Section 3

Installation position

Basically, the sensors can be operated in any position. However, it must be ensured that the pipe is completely filled and the sensor is not in a position where the turbulence of the medium is heavy, causing the formation of air bubbles.

The following graph shows the favoured installation locations for the sensor. Here, assembly on the side of the pipe is preferable.

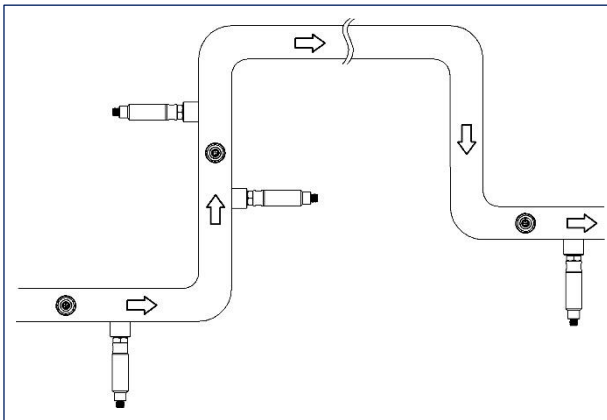

Fig. 7: Installation positions

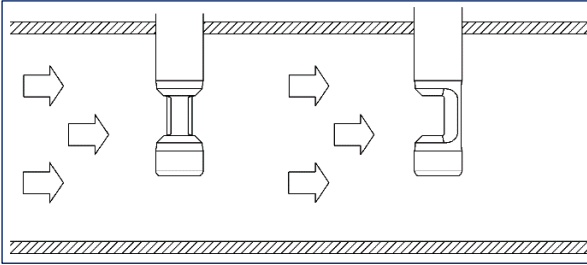

Fig. 8: Positioning the EXplore 131 in the media flow

2.3 Checking the sensors

Filters (EXplore 131) or comparison standards (EXplore 171) with various reference values are available for testing the EXplore sensors. If required, they can be attached to the sensor. In order to guarantee fault-free testing, it must be ensured that

- the optical sensor unit is dry and clean.
- the reference filter or the reference standard is placed precisely on the sensor.
- the marking (arrow) for the standard is aligned with the middle of the identification plate of the EXplore 171.
- the side with the filter insert is located on the lower measurement window (EXplore 131).

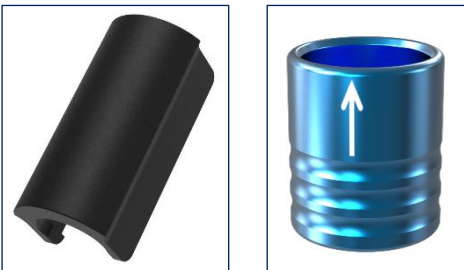

Fig. 9: Reference filter or reference standard with marking

3 Ordering structure

3.1 Explore 131

		Code	Measurement range				
		A	0...100% turbidity				
			Code	Optical path length			
			05	5 mm			
			10	10 mm			
			20	20 mm („VRN“ ≥ DN50)			
			Code	Material (fluid-wetted)			
			4435	Stainless steel 1.4435 / 316 L			
			Code	Sealing material (fluid-wetted)			
			MET	Metal sealing (without elastomer)			
			Code	Process connection			
			G12	Thread G ½" (metal sealing)			
			T15	Tri-Clamp 1,5" (EHEDG/3A)			
			T20	Tri-Clamp 2" (EHEDG/3A)			
			VRN	Varivent N (EHEDG/3A) DN40-125			
			Code	Interface			
			A4	Analogue 4...20 mA			
EXplore 131							Order number

3.2 EXplore 171

		Code		Measurement range		
		A	0...100% turbidity			
		Code		Material		
		4435	Stainless steel, 1.4435 (316L)			
		Code		Sealing material (fluid-wetted)		
		MET		Metal sealing (without elastomer)		
		Code		Process connection		
		G12		Thread G1/2" (metal sealing)		
		T15		Tri-Clamp 1,5" (EHEDG/3A)		
		T20		Tri-Clamp 2" (EHEDG/3A)		
		VRN		Varivent N (EHEDG/3A) DN40-125		
		Code		Interface		
		A4		Analogue 4...20 mA		
EXplore 171					Order number	

4 Spare parts and accessories

The sensor serial number must always be quoted for spare parts and accessories orders.

4.1 Accessories

Description	Order number
Connection cable 2 m (M12 5-pin)	2-125-00-001
Connection cable 5 m (M12 5-pin)	2-125-00-002
Connection cable 10 m (M12 5-pin)	2-125-00-003
Set reference filters EXplore 131 (incl. certificate)	2-120-85-001
Set reference normal EXplore 171 (incl. certificate)	2-120-86-001

4.2 Certificates

Description	Order number
Certificate EN10204-2.2 for surface roughness (Ra <0.37 µm)	2-121-01-019
Certificate EN10204-3.1 for material	2-121-01-002

4.3 Factory inspection

Description	Order number
Factory recalibration for NIR sensors incl. certificate (recirculation proof)	2-999-00-013

4.4 Installation adapter

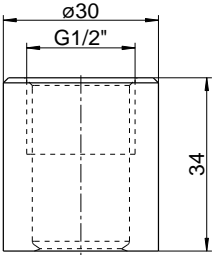
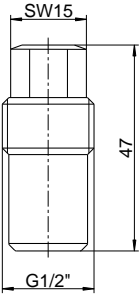
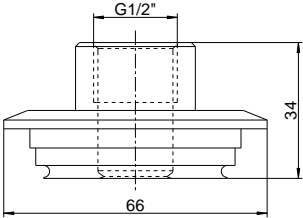
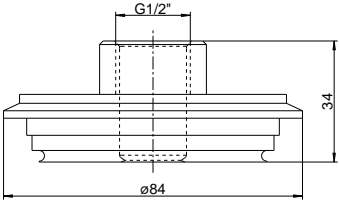
Description	Drawing	Order number
Welding sockets G 1/2" cylindrical		2-087-33-003
Brass G 1/2" shrink-wrap aid		2-086-33-003
Process adapter Varivent F DN 25-40		2-083-33-001
Process adapter Varivent N DN 40-125		2-083-33-002

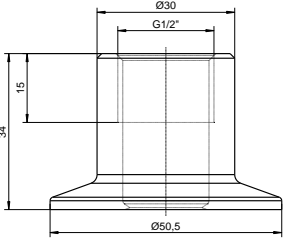
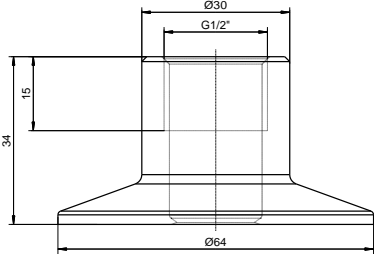
Description	Drawing	Order number
Process adapter Tri-Clamp 1 1/2"		2-083-33-005
Process adapter Tri-Clamp 2"		2-083-33-006

5 Certificates and compliances

All freely available certificates and conformities can be found in their most current form in the "Downloads" section of our website.

To access the following address, enter it into your browser or scan the QR code below. Then select the relevant product and document from the list.

<https://e-p-e.com/en/downloads>



Depending on the product, additional certificates (e.g. material, surface, etc.) are available. If necessary, please send a corresponding request to Exner Process Equipment GmbH.



Exner Process Equipment GmbH
Carl-Metz-Str. 26
D-76275 Ettlingen
Germany

tel +49 (0)7243-94 54 29-0
fax +49 (0)7243-94 54 29-99
mail info@e-p-e.de

www.e-p-e.com