

Explore 131 / 171

OPERATING INSTRUCTIONS

NIR Turbidity Sensors



All brand and product names are registered trademarks of
EXNER PROCESS EQUIPMENT GmbH

Imprint

Issued by:

Exner Process Equipment GmbH

Carl-Metz-Str. 26

D-76275 Ettlingen

Issue date: 2024-10-15

Effective: 01.07.2024

Article number: 9-901-85-002

File: Operating instructions EXplore 131_171 240701

© 2020, Dipl.-Ing. [Graduate Engineer] Detlef Exner

All rights reserved, also for the translation.

The contents of these operating instructions may only be reproduced with written approval from EXNER PROCESS EQUIPMENT GMBH, ETTLINGEN.

All technical specifications, drawings, etc. are subject to copyright protection law.

We reserve the right to make technical changes.

Printed on chlorine and acid-free paper consisting of cellulose pulp.

Table of contents

1 General.....	6
1.1 Manufacturer.....	6
1.2 Depiction of information.....	6
2 Security and protection measures.....	9
2.1 General safety instructions.....	9
2.2 Intended use.....	9
2.3 Danger zones and residual dangers.....	10
2.4 Equipment and accessories.....	10
2.5 Requirements of the staff.....	10
2.6 Pictograms.....	11
3 Technical data.....	12
3.1 Standards.....	12
3.2 Specification.....	12
3.3 Dimensions.....	13
3.4 Environmental conditions.....	13
3.5 EXplore process conditions.....	13
3.6 Identification plate.....	14
4 Product description.....	15
4.1 NIR EXplore turbidity sensors.....	15
4.1.1 Components EXplore 131.....	15
4.1.2 EXplore 171 components.....	16
4.2 Process integration.....	17
4.3 Checking the sensors.....	20

- 5 Delivery.....21
 - 5.1 Scope of delivery 21
 - 5.2 Checking the delivery..... 21

- 6 Assembly..... 22
 - 6.1 Preparing the plant..... 22
 - 6.2 Mechanical connection..... 22
 - 6.3 Electrical connection 23

- 7 Servicing 25
 - 7.1 Important service notes..... 25
 - 7.2 Control process connection 25
 - 7.3 Clean the measuring window / lens 26
 - 7.4 Maintenance plan27

- 8 Troubleshooting in case of problems..... 28
 - 8.1 No or faulty measurement..... 28
 - 8.2 Heavily fluctuating measurement value..... 28
 - 8.3 Output current doesn't match the measurement value..... 28

- 9 Ordering structure 29
 - 9.1 EXplore 131..... 29
 - 9.2 EXplore 171..... 30

- 10 Spare parts and accessories31
 - 10.1 Accessories..... 31
 - 10.2 Certificates..... 31
 - 10.3 Factory inspection..... 31
 - 10.4 Installation adapter 32

11 Disposal.....	34
12 Certificates and compliances.....	35

1 General

The operating instructions enable the safe and efficient handling of the turbidity sensors EXplore 131 and 171.

The operating instructions are part of the product and must be kept in its direct vicinity, accessible to the staff at all times. Before starting any work, the staff must have read and understood these operating instructions.

If these operating instructions incorporate suppliers' documentation (as an attachment), Exner Process Equipment assumes no guarantee for their contents, individual statements they include, technical data, etc.

1.1 Manufacturer

Exner Process Equipment GmbH
Carl-Metz-Str. 26
D-76275 Ettlingen

1.2 Depiction of information

In order to simplify working with and to increase the safety of these operating instructions, uniform safety information and icons are used.

Safety information

Safety information protects against damages to persons or materials. The measures described for averting danger must be adhered to.

The safety instructions are structured as follows:

SIGNAL WORD



Type and source of the danger

Consequences in case of non-observation

Prevention measures / Prohibitive rules

The components have the following meaning:

- Signal word: marks the severity of the danger
- Warning sign: draws attention to the danger
- Type and source of the danger: names the causes of the danger
- Consequences: describes the consequences in case of non-observation
- Measures: provides measures to avert the danger

DANGER



This warning message marks a danger with a high risk which results in death or severe injury if not avoided.

WARNING



This warning message marks a danger with a medium risk which can result in death or severe injury if not avoided.

ATTENTION



This warning message marks a danger with a low risk which can result in minor or moderate injury if not avoided.

NOTE

This note contains information regarding possible material or environmental damages which do not result in injury to persons.

Symbols

Marks	Meaning
»	Instruction with no specified sequence
1.	Instruction with a specified sequence
•	List
→	Reference to Chapter
" "	Operating element, Push button, Button
✓	Result

2 Security and protection measures

2.1 General safety instructions

The EXplore series sensors are designed in a way that when the operating instructions are observed the product does not present any hazards.

- Read the operating instructions first.
- Only install and operate the sensor after having read and understood all notes on its safe and proper use.
- Keep the operating instructions in a safe place in order to be able consult them at all times if required.
- Only use the sensor and its accessories if they are in good order and condition.
- Ensure the correct use of the sensor. Do not use it for applications for which it is not intended (e.g. as a step).
- Observe the laws, ordinances, regulations and standards applicable in the country of use and at the place of use.

2.2 Intended use

The EXplore series sensors are attached to tanks or pipes. The optical part of the sensors is immersed into the process fluid in order to measure physical properties via absorption or backscattering of irradiated light.

The sensor must be serviced regularly.

- Prepare a maintenance schedule for the respective process.
- Only perform maintenance work or repairs described in the operating instructions.
- Changes to the sensor may only be made after consulting with the manufacturer.

NOTE

The manufacturer is not liable for damages arising from improper or unintended use.

2.3 Danger zones and residual dangers

Sensors are connected to tanks and pipes which may be under pressure. Process liquid can only leak in case of negligent action or improper use. Therefore, depressurise the system and empty it or the plant component completely prior to disassembly of the sensor.

- Before start-up and after each maintenance, ensure that all seals and connections are complete and fully functional.
- Take appropriate protection measures prior to touching the sensor as parts of it may adopt the process temperature.

2.4 Equipment and accessories

Only use tested and approved equipment and accessories.

Seals

The EXplore series sensors do not require any elastomer seals. If you connect a sensor to your process via an adapter,

- » choose material properties of the process and O-ring seals depending on the process medium and cleaning liquid.
- » consider the swelling capacity and acid or base resistance of the sealing material.

2.5 Requirements of the staff

Qualification

Only have the sensor installed and serviced by trained staff!

Protective clothing

When starting-up or servicing, the operating staff must wear safety goggles and appropriate protective clothing.

Accident prevention regulations (UVV)

Please observe the rules and regulations concerning occupational safety in the country and place where the sensor is to be used!

2.6 Pictograms

For better orientation, pictographs and symbols are used in the operating instructions.

Pictogram	Meaning
	General warning sign

3 Technical data

3.1 Standards

The following standards were applied when manufacturing the sensor:

- EN 61326-1: 2013-7
- EN 61326-2-3: 2013-7
- DIN/EN 27027 (ISO7027)

3.2 Specification

Sensor specifications	
Measurement range	0...100 %
Resolution	0.1 %
Precision	± 1.5%
Reproducibility	≤ 1 % of the end value
Wavelength	850 nm
Light source	LED
Material	Stainless steel, 1.4435 (316L)
Surface finish	Ra <0.37 µm
Measuring window / Lens	Sapphire
Power supply	24 V DC
Output current	4...20 mA
Cable connection	M12 plug, 3-pin (5-pin also possible)
Process connection	G 1/2" für welding socket with 35 ° conus

3.3 Dimensions

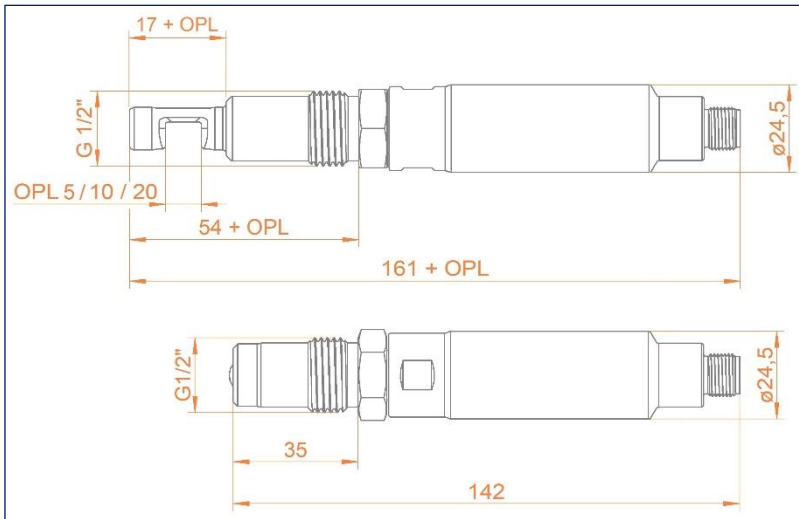

Fig. 1: Dimensions for sensors EXplore 131 (top) and EXplore 171 (bottom)

3.4 Environmental conditions

Ambient temperature -10...70 °C

Transport and storage temperature -20...80 °C

3.5 EXplore process conditions

Max. permissible pressure PS: 16 bar / 232 psi (EXplore 131)
20 bar / 290 psi (EXplore 171)

Max. permissible temperature TS: 90 °C (EXplore 131)
100 °C (EXplore 171)

Max. permissible sterilisation temperature: 135 °C max. 1 hour (EXplore 131)
135 °C max. 2 hours (EXplore 171)

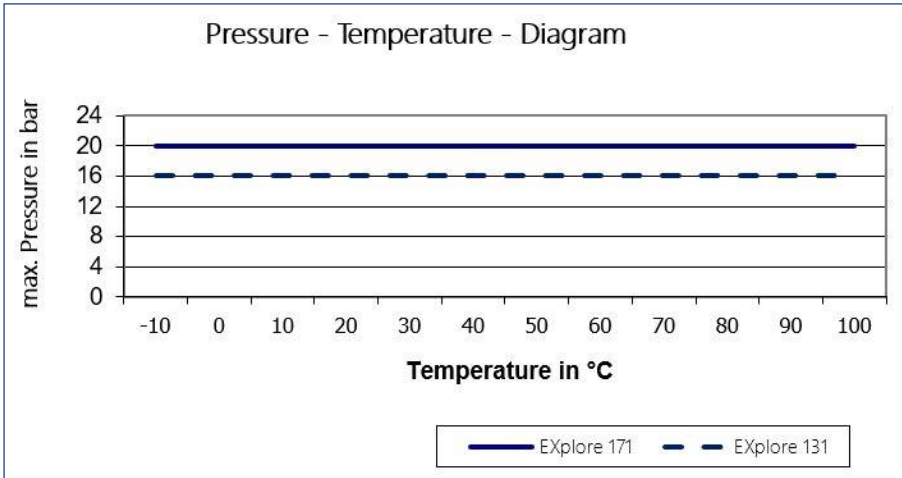

Fig. 2: Pressure temperature diagrams for EXplore

3.6 Identification plate

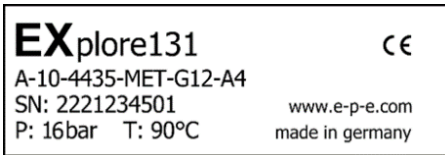

Fig. 3: Identification plate (based on EXplore 131)

In case of queries, please contact your retailer directly.

4 Product description

4.1 NIR EXplore turbidity sensors

4.1.1 Components EXplore 131

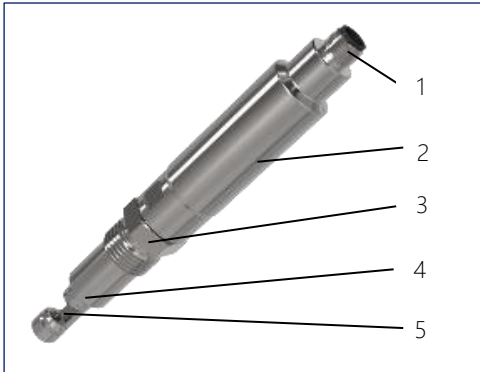

1	M12 plug connection
2	Transmitter
3	Pressure screw
4	Process connection
5	Measuring window

Fig. 4: NIR absorption sensor

EXplore 131

The NIR turbidity sensor EXplore 131 is a 180° absorption sensor which detects the turbidity of liquid in the close infrared range (850 nm wavelength). The sensor is designed to monitor continuous process results or safely show changes. Particularly suitable for phase separation, filter monitoring and concentration measurement.

- Safe phase separation
- Faster product change
- Filter monitoring
- Colour-independent concentration measurement
- Compact design with an integrated amplifier
- Resistant sapphire windows
- Hygienic design, CIP/SIP compliant
- LED light source, guarantees a stable and long-lasting signal

4.1.2 EXplore 171 components

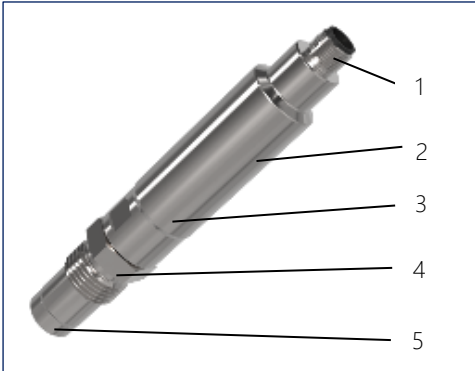

1	M12 plug connection
2	Transmitter
3	Pressure screw
4	Process connection
5	Sapphire lens (spherical)

Fig. 5: NIR backscatter sensor

EXplore 171

The NIR backscatter sensor EXplore 171 is designed to monitor the turbidity of liquids in order to monitor continuous process results or safely show changes. Particularly suitable for phase separation, filter monitoring and concentration measurement.

- Safe phase separation
- Faster product change
- Filter monitoring
- Colour-independent concentration measurement
- Compact design with an integrated amplifier
- Resistant sapphire lens
- Hygienic design, CIP/SIP compliant
- LED light source, guarantees a stable and long-lasting signal

4.2 Process integration

Sensor

The EXplore series sensors are installed directly in pipes or containers via its G ½" process connection or inserted in existing process connections using corresponding adapters.

The minimum possible pipe diameter depends on the selected process connection/adaptor as well as the insertion depth of the welding socket or the socket height for a tri-clamp connection.

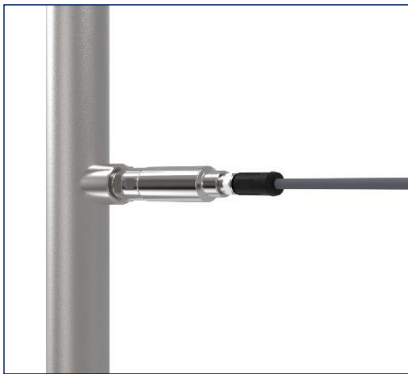
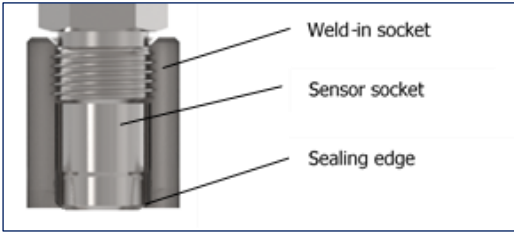

Fig. 6: Process integration

Welding sockets

Assembly using welding sockets guarantees hygienic process adaption which can be applied with minimal dead space and elastomer-free. As the system here uses purely metallic sealing, no further sealing materials such as elastomers may be used.



Please always use the welding aid sockets offered as accessories, so that the heat arising when welding can be safely dissipated and distortion of the borehole can be hindered effectively.



Welding in tanks / pipes

1. Drill a hole with the outer diameter of the welding aid socket (tolerance max. +0.2 mm)
2. Tack-weld the sockets using 4 evenly distributed points (Fig. 1, below)
3. Screw the welding aid sockets in
4. Weld the sections between the 4 points (Fig. 2, below)

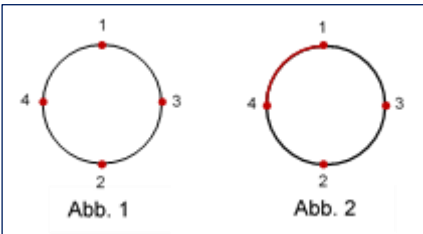
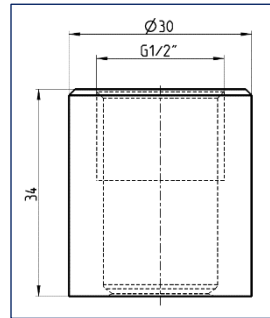

Transmitter

The transmitter is supplied with 24 V DC. It has an 4...20 mA output for measurement value output.

Pressure / Temperature

Depending on the sensor type, only a determined pressure-temperature range may be used. This can be found on the respective pressure/temperature diagram.

In order to protect the LED used, it is switched off as of a temperature of 90 °C (EXplore 131) or 100 °C (EXplore 171). Measurement is then no longer possible. After reduction of the media temperature below 90 °C (EXplore 131) or 100 °C (EXplore 171 °C), the LED is reactivated.

NOTE

Please observe the pressure and temperature diagram in → Section 3

Installation position

Basically, the sensors can be operated in any position. However, it must be ensured that the pipe is completely filled and the sensor is not in a position where the turbulence of the medium is heavy, causing the formation of air bubbles.

The following graph shows the favoured installation locations for the sensor. Here, assembly on the side of the pipe is preferable.

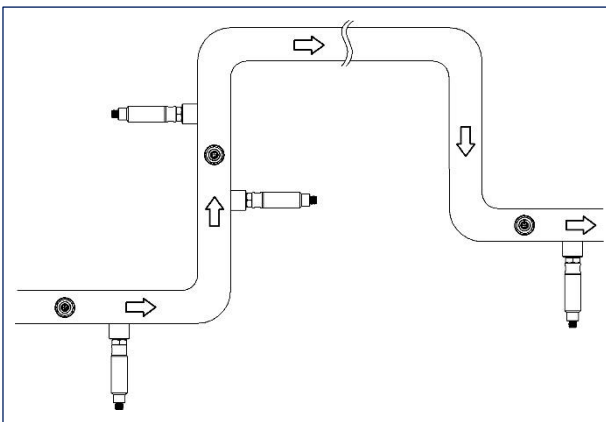

Fig. 7: Installation positions

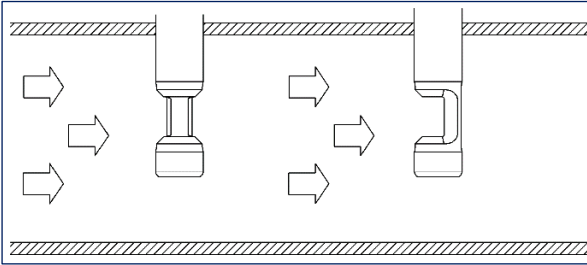

Fig. 8: Positioning the EXplore 131 in the media flow

4.3 Checking the sensors

Filters (EXplore 131) or comparison standards (EXplore 171) with various reference values are available for testing the EXplore sensors. If required, they can be attached to the sensor. In order to guarantee fault-free testing, it must be ensured that

- the optical sensor unit is dry and clean.
- the reference filter or the reference standard is placed precisely on the sensor.
- the marking (arrow) for the standard is aligned with the middle of the identification plate of the EXplore 171.
- the side with the filter insert is located on the lower measurement window (EXplore 131).

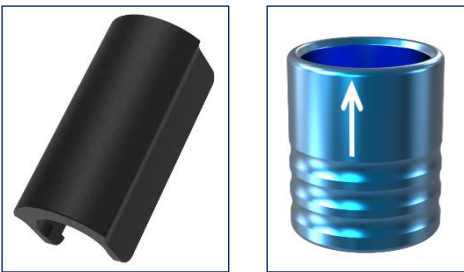

Fig. 9: Reference filter or reference standard with marking

5 Delivery

5.1 Scope of delivery

The sensor is inspected at the factory and delivered ready for installation in packaging which provides optimal protection for the sensor.

The delivery includes:

- Sensor EXplore
- Protective sleeve for measurement optics
- Operating instructions
- Certificate for the surfaces (optional)

NOTE

Store the sensor in the packaging. This ensures optimal protection until it is installed.

5.2 Checking the delivery

Before you release the sensor for assembly, please ensure the following:

- Packaging and device are in apparent good order and condition.
- The identification plate of the sensor corresponds to the order specifications (→ Chapter 3.6 "Identification plate").

In case of queries, please contact your retailer directly.

6 Assembly

6.1 Preparing the plant

Requirements:

- Sufficient working space is available for operation of the sensor.
- The process is deactivated.
- The containers or pipes are depressurised, empty and clean.
- The connection socket and process connection must match.
- The pipe is earthed.

6.2 Mechanical connection

ATTENTION

Danger of injury due to escaping process liquid!

Scalding or chemical skin burns, depending on the properties of the process liquid.



- » Check whether the containers or pipes where the sensor is connected are depressurised, empty and clean!

Sensors with process connection Thread G1/2" (Code: G12):

- » Use the matching process glands with 35° sealing cone (also refer to → Chapter 10 Spare parts and accessories)
- » Tighten the pressure screw (see Figs. 4 & 5) to 10-20 Nm.

NOTE

The open gap of the absorption sensor is aligned with the middle of the identification plate.

Sensors with process connection compliant to EHEDG/3A (Code: T15 / T20 / VRN):

- » Please note the additional information for hygienic installation which is described in the "EHEDG & 3A supplementary sheet".

6.3 Electrical connection

Requirements:

- Use an original cable with the correct connector plug.

NOTE

Also, ensure that the connection line only runs within one building, does not leave it and has a maximum line length of <30 metres.

Connecting the sensor:

The colour coding specified is in accordance with the Exner accessories. The corresponding pin assignment can be taken from the following figures.

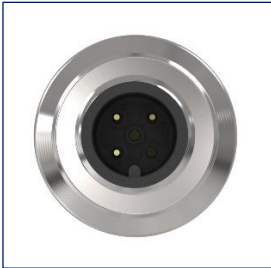
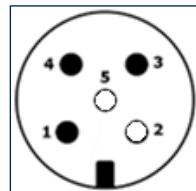

Fig. 10: Plug connection at the sensor (3-pin)

3-pin M-12 plug (view according to Fig. 10)

Pin	Colour	Designation
1	Brown	DC + (24 V DC)
3	Blue	DC – (GND)
4	Black	Analogue output (4-20 mA)



- » Insert the M12 plug into the sensor's plug socket and tighten the union nut hand-tight. When loosening the cable, use a suitable tool to counter the wrench flat of the sensor.

7 Servicing

7.1 Important service notes

- Prepare a maintenance schedule for the respective process.
- Only trained personnel is allowed to perform maintenance work.
- Always wear appropriate protective clothing when performing maintenance work.
- Only perform maintenance work or repairs described in the operating instructions!
- Changes to the design may only be carried out after consulting with the manufacturer.
- Before removing the sensor from the process, pipes and tanks must be depressurised, empty and clean.

7.2 Control process connection

The sensor is held in the process gland via the pressure screw (see Figs. 4 & 5) and sealed.

NOTE

Check regularly whether the process connector is sealed. If necessary, re-tighten the pressure screw.

WARNING



Process liquid escapes from the process connection!

Danger dependent on the properties of the process medium!

- » Tighten the pressure screw with 10-20 Nm.

7.3 Clean the measuring window / lens

The turbidity of the process medium is measured from two measuring windows or a sapphire spherical lens in the process. Impurities or coating falsify the measurement value.

Clean coatings off the lens regularly.

1. Remove the sensor from the process connection.
2. Clean coatings off the measuring window or the lens regularly.
3. Check the measuring window or the lens for possible damages.

ATTENTION



Danger of injury due to escaping process liquid!

- » Wear protective goggles and protective clothing!
- » Check whether the containers or pipes where the sensor is connected are depressurised, empty and clean!



Fig. 11: Measuring window at the sensor



Fig. 12: Ball lens at the sensor

7.4 Maintenance plan

Perform the servicing work at recommended intervals!

Interval	Work
Every three months	<ul style="list-style-type: none">» Make a visual inspection of the leak-tightness of the process connection.» Tighten the pressure screw with 10-20 Nm.
Yearly	<ul style="list-style-type: none">» Remove the sensor and clean the measuring window or ball lens.

8 Troubleshooting in case of problems

8.1 No or faulty measurement

Possible cause	Remedy
No power supply on the sensor	<ul style="list-style-type: none"> » Test / make the electrical connection according to → Chapter 6.3 » Check the connection line
Measuring window / Lens is soiled	<ul style="list-style-type: none"> » Clean the measuring window / lens → Chapter 7.3

8.2 Heavily fluctuating measurement value

Possible cause	Remedy
Air bubbles in the system	<ul style="list-style-type: none"> » In order to ensure media flow without or with a few air bubbles, bleed the system accordingly as applicable
Sensor doesn't immerse fully in the process fluid	<ul style="list-style-type: none"> » Change the installation location

8.3 Output current doesn't match the measurement value

Possible cause	Remedy
Current output parameterisation faulty	<ul style="list-style-type: none"> » Send the sensor to the manufacturer for testing
Analogue output not connected	<ul style="list-style-type: none"> » Test / make the electrical connection according to → Chapter 6.3 » Check the connection line

9 Ordering structure

9.1 Explore 131

		Code	Measurement range				
		A	0...100% turbidity				
			Code	Optical path length			
			05	5 mm			
			10	10 mm			
			20	20 mm („VRN“ ≥ DN50)			
			Code	Material (fluid-wetted)			
			4435	Stainless steel 1.4435 / 316 L			
			Code	Sealing material (fluid-wetted)			
			MET	Metal sealing (without elastomer)			
			Code	Process connection			
			G12	Thread G ½" (metal sealing)			
			T15	Tri-Clamp 1,5" (EHEDG/3A)			
			T20	Tri-Clamp 2" (EHEDG/3A)			
			VRN	Varivent N (EHEDG/3A) DN40-125			
			Code	Interface			
			A4	Analogue 4...20 mA			
Explore 131							Order code

9.2 EXplore 171

		Code	Measurement range		
		A	0...100% turbidity		
			Code	Material	
			4435	Stainless steel, 1.4435 (316L)	
			Code	Sealing material (fluid-wetted)	
			MET	Metal sealing (without elastomer)	
			Code	Process connection	
			G12	Thread G1/2" (metal sealing)	
			T15	Tri-Clamp 1,5" (EHEDG/3A)	
			T20	Tri-Clamp 2" (EHEDG/3A)	
			VRN	Varivent N (EHEDG/3A) DN40-125	
			Code	Interface	
			A4	Analogue 4...20 mA	
EXplore 171					Order code

10 Spare parts and accessories

The sensor serial number must always be quoted for spare parts and accessories orders.

10.1 Accessories

Description	Order number
Connection cable 2 m (M12 5-pin)	2-125-00-001
Connection cable 5 m (M12 5-pin)	2-125-00-002
Connection cable 10 m (M12 5-pin)	2-125-00-003
Set reference filters EXplore 131 (incl. certificate)	2-120-85-001
Set reference normal EXplore 171 (incl. certificate)	2-120-86-001

10.2 Certificates

Description	Order number
Certificate EN10204-2.2 for surface roughness (Ra <0.37 µm)	2-121-01-019
Certificate EN10204-3.1 for material	2-121-01-002

10.3 Factory inspection

Description	Order number
Factory recalibration for NIR sensors incl. certificate (recirculation proof)	2-999-00-013

10.4 Installation adapter

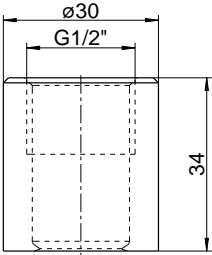
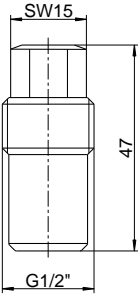
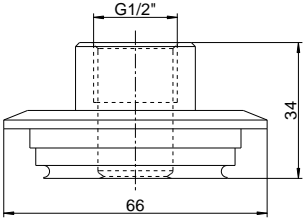
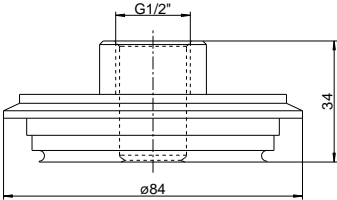
Description	Drawing	Order number
Welding sockets G 1/2" cylindrical		2-087-33-003
Brass G 1/2" shrink-wrap aid		2-086-33-003
Process adapter Varivent F DN 25-40		2-083-33-001
Process adapter Varivent N DN 40-125		2-083-33-002

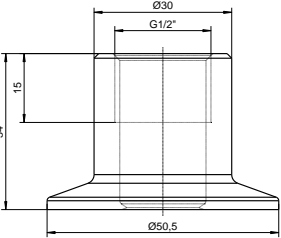
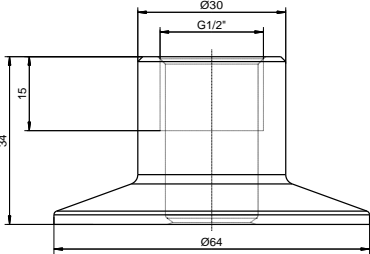
Description	Drawing	Order number
Process adapter Tri-Clamp 1 1/2"		2-083-33-005
Process adapter Tri-Clamp 2"		2-083-33-006

11 Disposal

Sensor

Make sure that the sensor is free of hazardous and toxic substances. Components must be disposed of separately in accordance with their respective materials.

Please observe the valid rules and regulations concerning disposal in the country and place of application.

Packaging

The packaging material is cardboard and can be disposed of as waste paper.

12 Certificates and compliances

All freely available certificates and conformities can be found in their most current form in the “Downloads” section of our website.

To access the following address, enter it into your browser or scan the QR code below. Then select the relevant product and document from the list.

<https://e-p-e.com/en/downloads>



Depending on the product, additional certificates (e.g. material, surface, etc.) are available. If necessary, please send a corresponding request to Exner Process Equipment GmbH.



Exner Process Equipment GmbH
Carl-Metz-Str. 26
D-76275 Ettlingen
Germany

tel +49 (0)7243-94 54 29-0
fax +49 (0)7243-94 54 29-99
mail info@e-p-e.de

www.e-p-e.com