

## Contents

---

1	What's in the box.....	2
2	Preparing the system.....	2
3	Connecting and disconnecting wires to the terminal blocks on SME electronics.....	3
4	Connecting sensor probe to transmitter electronics.....	5
5	Powering the Transmitter.....	6
6	Connecting 4-20 mA outputs.....	7
7	Connecting Modbus RTU (RS-485) outputs.....	8
7.1	General.....	8
7.2	USB.....	8
7.3	4-20mA.....	8
7.4	Modbus TCP and RTU.....	8
7.5	Bluetooth.....	8
7.6	HART.....	9
7.7	Ethernet/IP.....	9
7.8	Profinet.....	9
8	Operating the system.....	9
8.1	Viscosity and density measurement.....	10
8.2	Sensor installation recommendation.....	10
9	Handling the Sensor.....	11
9.1	Cleaning the sensor.....	12
10	Notes/Errata:.....	13

## 1 What's in the box

The following items are delivered with the SRD system:

- Sensor cable
- Electronic transmitter, SME
- SRD sensor probe
- USB stick with software tool installer
- Cable glands (optional)



## 2 Preparing the system

The sensor measurement system consists of two components:

- SRD Sensor Probe
- SME Sensor Transmitter (Electronics unit)

The transmitter is shipped fully assembled. Gain access to the connections by unscrewing the cover and removing the display (if ordered with display) by pulling it out. The SME electronics module is now accessible for connecting the sensor, power, and communication cables.

### 3 Connecting and disconnecting wires to the terminal blocks on SME electronics

The wires are generally color coded, the ends should be crimped with 8mm diameter crimps. This connection is valid for sensor cable, power cable, Modbus cable, 4-20 mA cables.

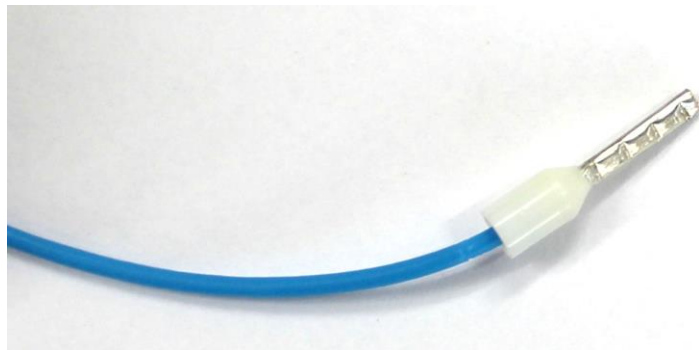
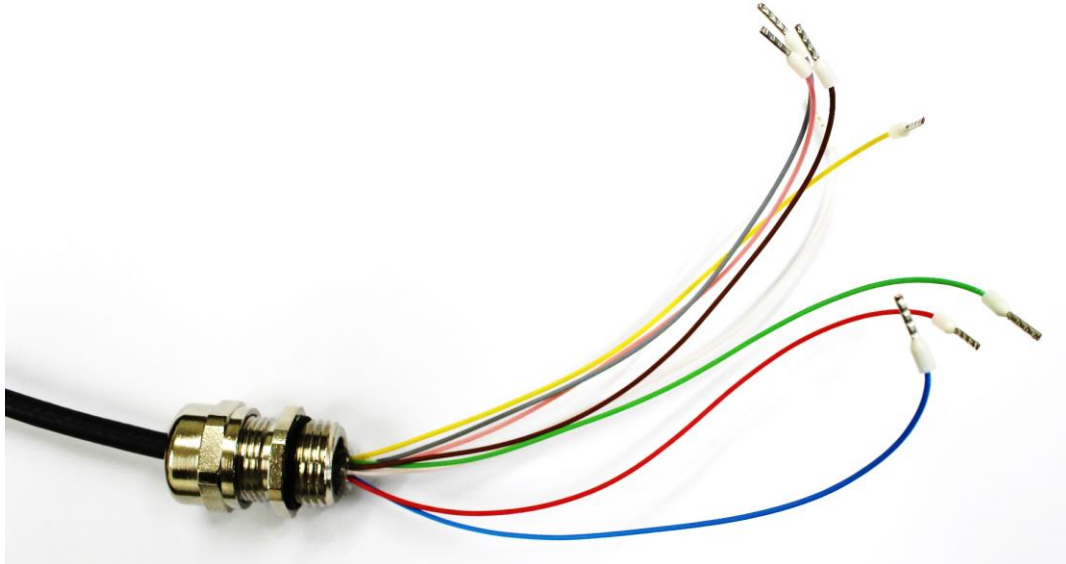

To connect the wires, insert the crimped end in the correct port on the terminal block till it clicks firmly in place and cannot be pulled out when tugging on the wires (do not tug on the wires with a lot of force as that may damage the terminal block).

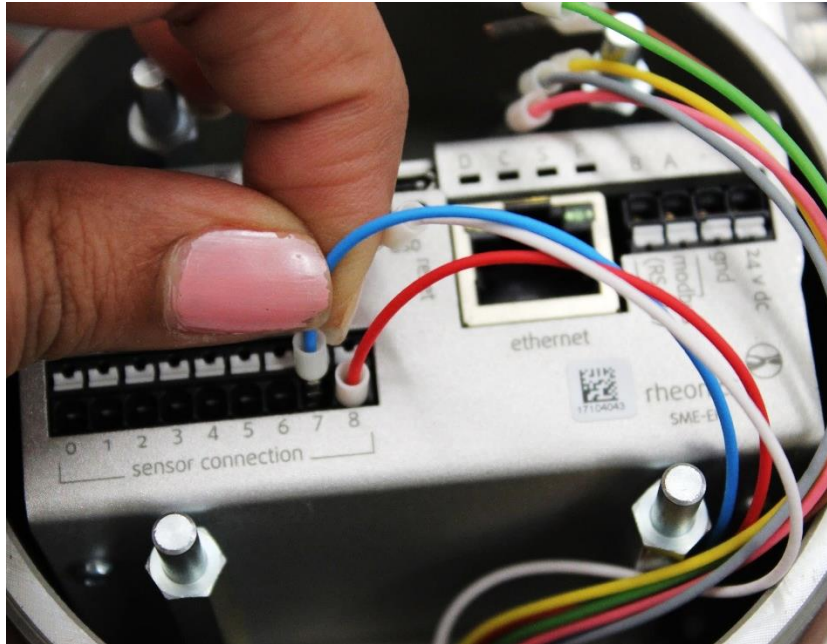

To disconnect the sensor wires, press the white tab for that specific port with a small flat screw driver as shown in picture below where the user is removing wire connected to port 1.

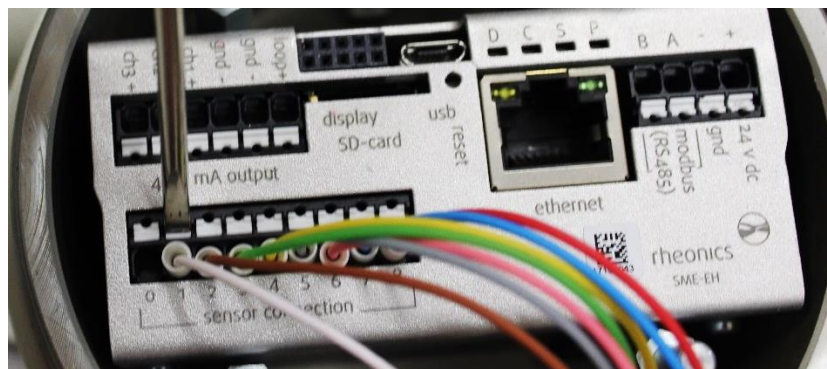

While pressing on the white part, pull out the cable connection with the other hand as shown in the picture below.



#### 4 Connecting sensor probe to transmitter electronics

The sensor probe is connected to the transmitter electronics by a sensor cable. Follow the color code table below to connect the correct wires from the sensor cable to the sensor connection terminal strip on the transmitter. The leads are delivered with crimped ends; cable can be shortened if needed, but sleeves should be crimped on the stripped ends.

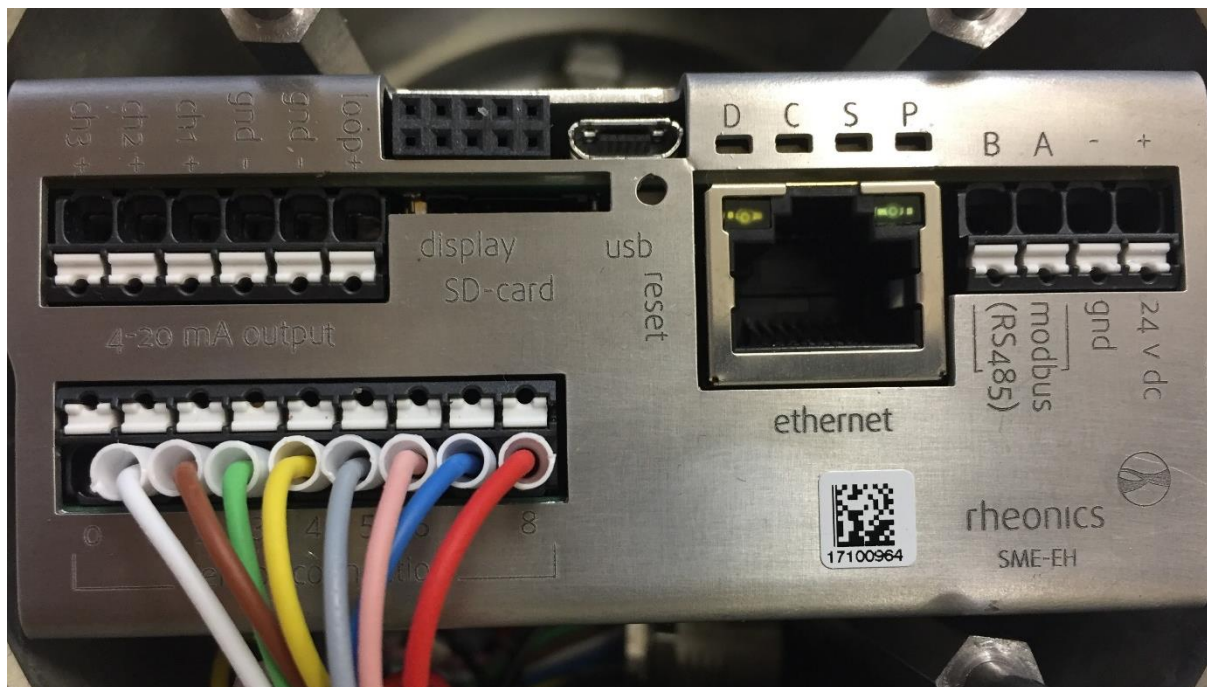

Wire Color	Sensor connection terminal #
Red	8
Blue	7
Pink (Rose)	6
Grey	5
Yellow	4
Green	3
Brown	2
White	1
---not connected---	0

## 5 Powering the Transmitter

Connect a 24V DC supply to the power input terminals on the transmitter.

Power input terminals are labeled with 24 V DC + and – GND.

It is important to avoid ground loops in the setup / plant where the SME is used. Ground loops can lead to excessive currents on the ground / return wire of the SMEs 24V power supply which can damage the unit.

To prevent this, we strongly recommend that the SME is powered by a separate 24V power supply with galvanic separation. Otherwise, the SMET might be permanently damaged.

## 6 Connecting 4-20 mA outputs

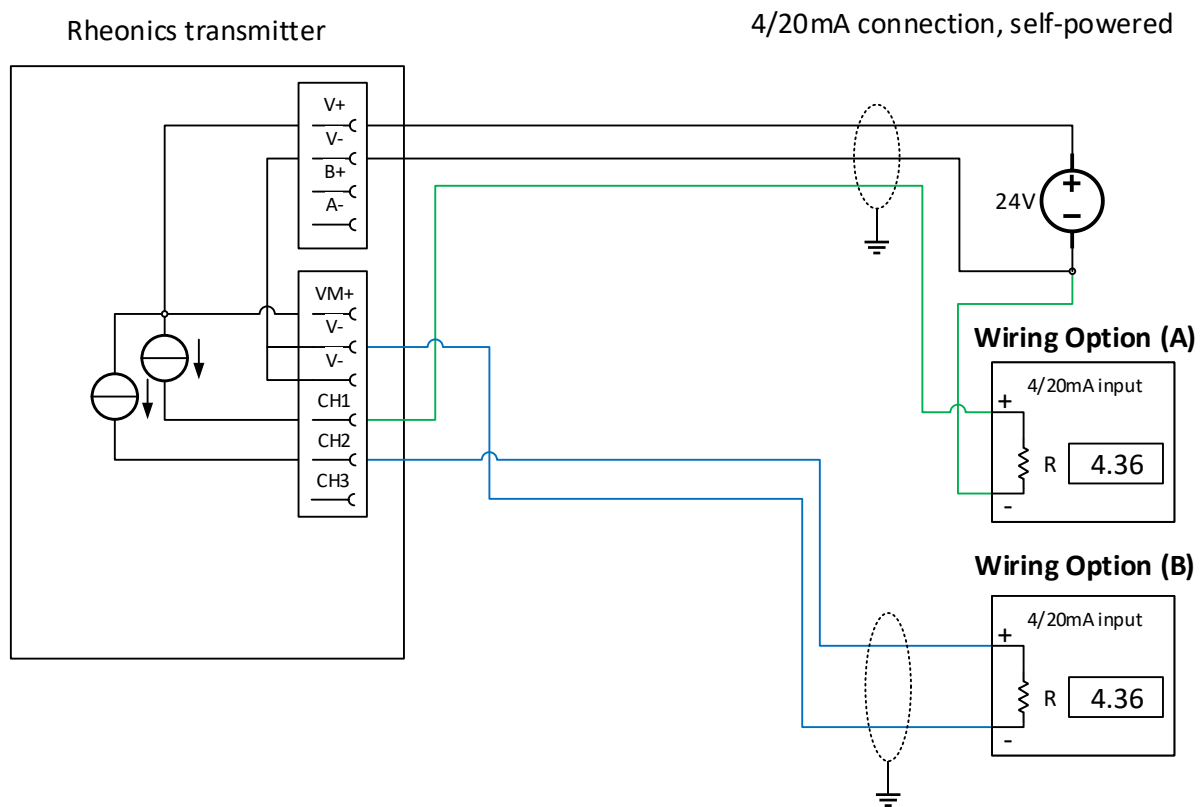

**Load impedance:** 0 to 720 Ohms

**Output range:** 4-20mA, (3.5mA error)

**Galvanic isolation:** none

### Wiring Option (A)

- Connect positive terminal of current input module to desired channel terminal of SME device
- Connective negative terminal of current input module to negative power supply terminal used for SME device

### Wiring Option (B)

- Connect positive terminal of current input module to desired channel terminal of SME device
- Connective negative terminal of current input module to V- terminal of SME device

### Notes

- The 4/20mA outputs are not galvanically isolated. It is not recommended to route the 4/20mA to off-site locations if the corresponding 4/20mA input does not provide galvanic isolation.

## 7 Connecting Modbus RTU (RS-485) outputs

---

### 7.1 General

Rheonics electronics are extremely easy to integrate and are stable in harsh conditions. They are operational in high EMI environments and can operate up to 65 °C. With the ability to operate efficiently in high Electromagnetic Interference (EMI) settings, providing reliable real-time data acquisition

To enhance flexibility and convenience for our customers across diverse industries, we provide a comprehensive array of communication protocols.

### 7.2 USB

USB communication is commonly used for a first configuration for the electronics, also really helpful for training new users. All Rheonics sensor electronics (SME) come with a standard USB micro B port. Rheonics provides an RS232 over USB. Check this support article: [USB](#)

### 7.3 4-20mA

4-20 mA analog communication is commonly used in the industry because of its versatility. It uses just 2 wires to transmit the signal from the sensor to the electronics. It is not overly susceptible to noise and is highly accurate. Check this support article: [4-20 mA](#)

### 7.4 Modbus TCP and RTU.

Rheonics SME devices offer the Modbus RTU and TCP service over the RS485 and Ethernet interface. For Modbus RTU, In Modbus TCP, the Modbus message service provides Client-Server communication between devices connected on an Ethernet TCP IP network. Check this support article: [Modbus TCP \(Ethernet\)](#)

Modbus RTU is a serial communication protocol that utilizes a compact binary representation, simplifying implementation over RS-232 or RS-485 interfaces, and only requires 2 wires. Check this support article: [Modbus RTU \(RS-485\)](#)

The data is exchanged in the form of registers. Once you understand how the data is delivered, the integration and management are easy to do. This interface allows interoperability between devices from different manufacturers.

Check our Modbus User manual:

[Modbus RTU.](#)

[Modbus TCP/IP.](#)

### 7.5 Bluetooth

Rheonics support Bluetooth 4.0 in all SME-TRD devices. Using this technology, sensors can transmit data wirelessly without the need for wires, USB converters, WIFI, smartphones, or any other connection. A unique feature of Bluetooth communication is that there are no wires necessary for communications, allowing for place-specific data transmission.



## 7.6 HART

All SME devices offer HART protocol communication option. Its most notable advantage is that it can communicate over legacy 4–20 mA analog instrumentation current loops.

It delivers 4 parameter readings, that is, density, viscosity, and temperature over a single analog signal channel. Check this support article: [HART](#)

Check our HART User manual: [https://rheonics.com/wp-content/uploads/2022/06/Rheonics-HART-Manual\\_V2.3.pdf](https://rheonics.com/wp-content/uploads/2022/06/Rheonics-HART-Manual_V2.3.pdf)

## 7.7 Ethernet/IP

Ethernet/IP is a protocol that is widely used in the industry for fast communication as it can deliver a large amount of data and multiple parameters coming from the sensor.

It is commonly used with Allen Bradley PLC. Rheonics has extensive expertise with this protocol and provides guidelines through its support portal on how to easily integrate the sensors with this communication protocol. Check this support article: [Ethernet/IP](#)

Check our Ethernet/IP User manual: <https://cdn.rheonics.com/wp-content/uploads/2022/06/Rheonics-EthernetIP-v2.1.pdf>

## 7.8 Profinet

PROFINET offers several benefits over traditional fieldbus systems, including faster communication speeds, higher bandwidth, and increased flexibility. It also allows remote diagnostics and maintenance, which can reduce downtime and increase productivity. Check this support article: [PROFINET](#)

Check our Profinet User manual: [https://rheonics.com/wp-content/uploads/2022/03/Profinet-rheonics\\_manual\\_V1.0.pdf](https://rheonics.com/wp-content/uploads/2022/03/Profinet-rheonics_manual_V1.0.pdf)

# 8 Operating the system

---

After installing the software and setting up the port, the system may now be started. The installation of the Rheonics Control Panel (RCP) Software and its settings are described in the RCP manual.

**THE ELECTRONIC BOX MUST BE ATTACHED TO THE COMPUTER WITH THE USB CABLE AND POWERED UP IN ORDER FOR THE SYSTEM TO OPERATE**

1. Connect the sensor to the Transmitter (instructions in section 2)
2. Connect power to Transmitter (instructions in section 3)
3. Connect the micro USB cable to the Transmitter electronics. Connect the other end to a free USB port on the computer.

- Now that the proper operating mode has been established, run the Rheonics Control Panel software. The Rheonics Control Panel application is opened from the Start menu.



When the software is running, you will see a screen similar to the following:

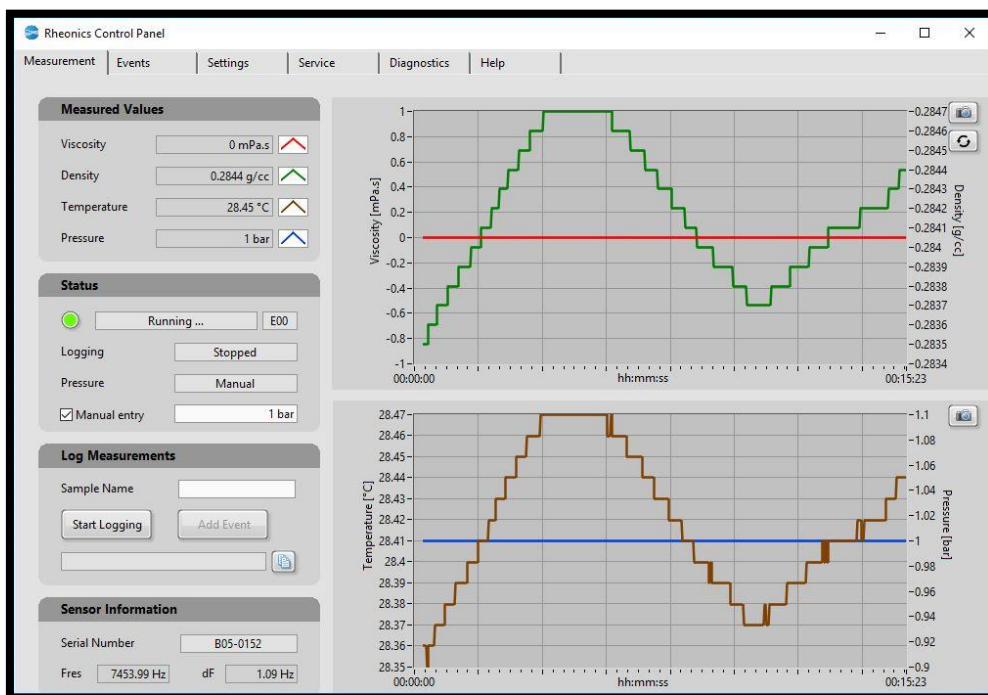

For help about the Rheonics Control Panel (RCP) and its settings see:  
 Help -> RCP – Rheonics Control Panel Software manual

## 8.1 Viscosity and density measurement

The SRD measures the density and viscosity of the fluid. The RCP will give you the density, viscosity and temperature data when connected to the sensor.

## 8.2 Sensor installation recommendation

To ensure the measured data from the SRD is in line with factory calibration, the installation should ensure that there is sufficient fluid volume around the sensor as shown below. There should not be any surface except the fluid being measured in this mentioned space surrounding the sensor.

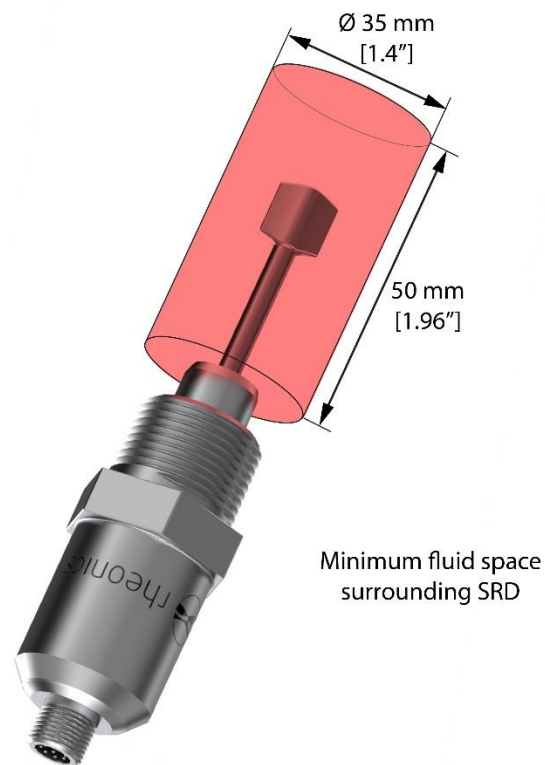

## 9 Handling the Sensor

---

The SRD is a stable, robust sensor system that operates over a wide range of temperatures and pressures. The sensor is made of 316L stainless steel, which resists attack by a wide variety of highly corrosive fluids.



In order to get optimum performance from the system, some simple guidelines must be followed.

## 9.1 Cleaning the sensor

The SRD is based on a resonant sensing element that operates in the range of approximately 7-8 kHz. The sensor measures viscosity in a thin layer of fluid surrounding the resonant element.

In any measurement scenario in which the sensor could become coated with tenacious fluids and solids, it is recommended that the sensor be removed and mechanically cleaned at appropriate intervals.

Adherent films can be removed by using appropriate solvents and/or wiping with solvent-saturated cloth or paper. Under no circumstances should abrasives be used to clean the resonator, as these will change the geometry and destroy its calibration.



Cleaning the sensor with solvent-saturated cloth or paper

After cleaning the sensor connect it to the electronics box and check that in air it gives the right air frequency and air damping as mentioned in the sensor info sheet.

Please note that it is difficult to get accurate measurement with plain water stationary in the SRD measurement area. Even degassed water tends to have air dissolved in it, which eventually forms micro bubbles on the surface of the sensor, disturbing its geometry. This is not a problem at higher pressures, which tend to re-dissolve any gases present. Hydrocarbons, glycols, and other fluids with low surface tension are less prone to bubble formation.

The SRD will operate in static fluids as well as flow rates in excess of 100 l/min. Flow may be in either direction, subject to the above caution about the effects of bubbles.

**Note: Do not use Ultrasonic cleaners.**

## 10 Notes/Errata:

---